

# ELFOEnergy VULCAN Medium

High efficiency air cooled reversible heat pump for outdoor installation

## WBAN 82-302 RANGE

Nominal heating capacity (**A7/W45**) from 29,1 to 99,5 kW

Nominal cooling capacity (**A35/W7**) from 21,3 to 80,3 Kw



VULCAN Medium is a high temperature heat pump series representing ideal single solution for **heating, cooling and sanitary hot water production for centralised systems**, such as in **blocks of apartments, hotels and for use with collective applications in general**.

- **A CLASS Energy Efficiency according to Eurovent** in heating.
- **Ideal for all plant types** including radiator systems using hot water produced at a temperature of up to 65°C, and ambient air at -7°C.
- **A simplified system** thanks to the use of a single generator for heating and cooling that eliminates the risks and obligatory maintenance costs associated with traditional combustion systems.

The units in the ELFOEnergy VULCAN Medium range **can autonomously produce sanitary hot water and are set up for use in combination with solar panel storage tanks**, thus **enabling the direct use of solar energy**.



Clivet partecipa al programma di certificazione EUROVENT fino a 1.500 kW. I prodotti interessati figurano nell'elenco dei prodotti certificati del sito EUROVENT [www.eurovent-certification.com](http://www.eurovent-certification.com)

# Heating, cooling and domestic hot water for blocks of apartments

## A great opportunity for renovation of present installation in the name of the reduction of consumption and energy efficiency

Heating and air-conditioning systems have seen radical changes both in technical and consumption terms in the tertiary sector and in collective applications over the last 15 years.

Recent European level normative regulations make these systems obsolete, inefficient and are causing demand for requalification investments from property administrators and managers to improve efficiency and reduce consumption and polluting emissions.



## Heat pump is ecological and consumption is -40% in terms of primary energy

Being able to heat harvesting the energy already in the air and a reduced amount of electricity, means consuming less on a global scale and not polluting the air in our cities.

If on one hand it is true that, in order to produce electricity, an electricity power plant uses fossil energy sources, such as, for example oil or gas, on the other hand, it is also true that this takes place in a larger plant which is therefore, more efficient, and constantly under control.

Tests have shown CO<sub>2</sub> emissions to be reduced by 50%.

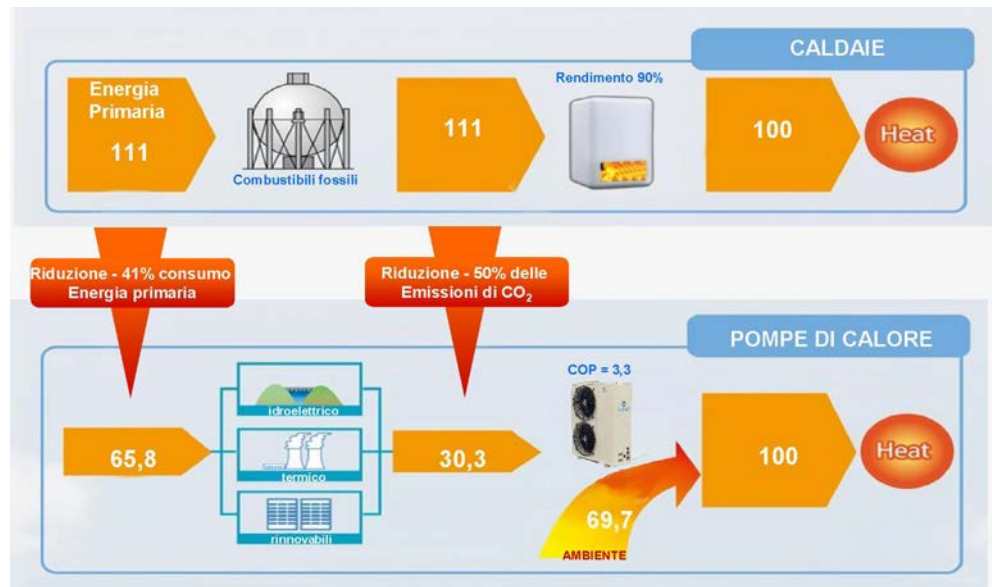

A purely indicative example elaborated from the White Paper on Heat Pumps edited by ANIMA COAER, Italian heat pump group. Primary energy equivalency / methane gas consumption: 0.0346 GJ/Nm<sup>3</sup> (lower heating value 9.6 kWh<sub>t</sub>/Nm<sup>3</sup>). Primary energy equivalency / electrical energy consumption: 0.001 GJ/kWh<sub>el</sub> (national electrical system yield 0.46 kWh<sub>el</sub>/kWh<sub>primary</sub>).

## Other advantages linked to the use of heat pumps instead of combustion boiler systems

	Reduction in consumption and operating costs		Elimination of gas adduction costs as well as combustible explosion risks		Elimination of chimney
	Reduction in CO <sub>2</sub> emissions		Elimination of legally obligatory maintenance costs (ISPESL)		

# Main advantages given by ELFOEnergy VULCAN Medium

## Unique solution

The ELFOEnergy VULCAN Medium is a reversible-cycle heat pump adapted for heating, cooling and the production of sanitary hot water.

### Complete management of production and storage of sanitary hot water:

- the three-way valve for the domestic hot water can be supplied INTEGRATED into the unit
- "CAC SX Sanitary hot water Control kit" accessory for the management of the domestic hot water tank (tank not supplied by Clivet).



## Efficiency

ELFOEnergy VULCAN units have been developed to obtain the maximum energy EFFICIENCY both in full and partial load conditions.

### ENERGY EFFICIENCY ACCORDING TO EUROVENT:

- Class A with COP heating > 3.2 (air at +7° and water at 45°C)
- Class A with COP heating > 4.05 (air at +7° and water at 35°C)

### Energy certification of the building

ELFOEnergy VULCAN Medium allows:

- In compliance with the minimum legal requirements for systems with heat pumps
- The achievement of high energy classes in the energy certification system



## Superior performance and technical characteristics

### ► Double refrigeration circuit

- Ensures safety since, in case of a breakdown in one of the two circuits, at least 50% of the capacity is guaranteed
- It enables better defrosting management for each circuit with a guarantee of 50% supplied capacity.
- It allows a wider operating limits during the production of sanitary water which may take place even at high ambient air temperatures.

### ► Separate ventilation to compensate for problems derived from prevailing winds.

### ► Its integrated hydronic group is easily accessible and separate from the refrigerant side.

### ► Standard Victaulic fittings for simple and fast installation



## Typical application field

Application	System typology	Production of domestic hot water	Product	Operating limits
 Blocks of residential flats  Hotels	Radiators Fan coil Radiant panels	Production of sanitary water is required	ELFOEnergy VULCAN Medium ELFOEnergy Vulcan can produce Sanitary Hot Water at high temperatures both in winter and summer conditions.  ELFOEnergy Vulcan can produce the correct temperature of water for cooling radiant panels	-18°C
 Public buildings	Radiators	Production of sanitary water is not required	ELFOEnergy VULCAN Medium	-18°C
 Office	Fan coil Radiant panels	Production of sanitary water is not required	ELFOEnergy Medium	-5°C using fan coils (water at 45°C) -10°C with radiant panels (water produced at 35°C)

(\*) note: if winter climatic conditions are sharper, the use of the ELFOEnergy VULCAN series is advisable.

## Mechanical controlled ventilation

**ELFOEnergy VULCAN Medium in combination with ELFOFresh<sup>2</sup> and/or ZEPHIR<sup>3</sup>:** an ideal match as well as a further opportunity for saving energy

By using fresh air and purification units like **ELFOFresh<sup>2</sup>** or **ZEPHIR<sup>3</sup>** with thermodynamic heat recovery, energy efficiency and savings are maximised.

Indeed, the heating capacity produced with these units, a reduction of the supply temperature from the ELFOEnergy VULCAN to the installations is possible, thus increasing the energy efficiency of the whole system.



**As a matter of fact, ELFOFresh<sup>2</sup> and ZEPHIR<sup>3</sup>, as well as handling and purifying the fresh air also supply an important energy contribution. For several months of the year (typically in spring and autumn) these units may be the sole Energy generator in the system.**

Even in the sharpest of winter seasons, the contribution made by **ELFOFresh<sup>2</sup>** and/or **ZEPHIR<sup>3</sup>**, enables a substantial reduction in the required capacity of ELFOEnergy VULCAN and consequently in the supply water temperature (considering equal exchange surfaces, such as radiators, etc.) in the system.

For these reasons, even if a check on the heated surfaces is always advisable in order to ensure sufficient coverage for heating needs with the water supply temperatures that are produced by the heat pump, the use of **ELFOFresh<sup>2</sup>** or **ZEPHIR<sup>3</sup>** is strongly recommended, especially for fresh air and energy requalification works.

## Talk large electronics

Characteristics of the new Talk Large card.

- Dynamic set point, controlled by the micro-processor:
- compensation of the number of ON/OFF cycles
- control of minimum set temperature differential to restart cycle
- set compensation for ambient temperature (if multi-function thermostat present in room).

Available sets:

- domestic hot water
- air conditioning system
- maintenance in standby phase

It also allows control/signalling of alarms in the refrigeration, water and electrical circuits

Control is also provided for the various unit functions, such as:

- pump/circulator and fan used with modulating signal
- second pump/circulator for control of system water
- control of exchange valve for domestic hot water or system through clean contact
- module for RS 485 signal from supervisor
- output ON/OFF or 0-10V for the integration auxiliary components control (electric heaters or boilers).



## Multi-function keypad

Main features of multi-function control:

Machine interface keypad.

Makes it possible to set up and operate the machine, with the same features as the 7 segment keypad, i.e. basic commands such as ON/OFF and mode change, and the ability to read the information that resides on the base such as states, parameters, and alarms.

Room timer-thermostat.

Detects the room temperature, both to compensate the water temperature and for room heat adjustment.

It also makes it possible to schedule the levels of room comfort over the course of the day or week.

The memory for scheduling resides in the room terminal, which is equipped with its own time.

System supervisor (HIDH1M).

The new terminal includes the system supervisor functions.

It is necessary in all cases in which the DHW(domestic hot water) module or the mixer module for radiant panels is present.

As an alternative, it can manage a clivet talk local network through a master-slave system implemented as a parameter on the main card via serial port.



# Standard unit technical specifications

## Compressor

Hermetic orbiting scroll compressor complete with motor over-temperature and over-current devices and protection against excessive gas discharge temperature. Fitted on rubber antivibration mounts and complete with oil charge.

An oil heater, which starts automatically, keeps the oil from being diluted by the refrigerant when the compressor stops.

## Structure

Structure made entirely in Zinc–Magnesium plate that guarantees excellent mechanical characteristics and high corrosion strength over time.

## Panelling

External pre-painted aluminium panelling that ensures superior resistance to corrosion for outdoor installation and eliminates the need for periodical painting. The panels can be easily removed to fully access internal components and are lined with sound-proof material on the inside to contain the unit's sound levels.

## Internal exchanger

Direct expansion heat exchanger, braze-welded AISI 316 stainless steel plates with large exchange surface and complete with external heat and anti-condensate insulation.

The exchanger is complete with:

- differential pressure switch, water side
- antifreeze heater to protect the water side exchanger, preventing the formation of frost if the water temperature falls below a set value.

## External exchanger

Finned exchanger, made from copper pipes arranged in staggered rows and mechanically expanded for better adherence to the collar of the fins. The fins are made from aluminium with a special corrugated surface, set a suitable distance apart to ensure maximum heat exchange efficiency.

The coils are complete with integral subcooling circuit which assures the correct refrigerant feeding of the expansion valve. Available in different options as per optional list.

## Fan

Low speed axial fan directly driven by single phase external rotor motor with incorporated thermal overload. Housed in aerodynamically shaped enclosures to increase the efficiency and reduce the noise level. Complete with fan guard in order to help against fortuitous contact with the blades.

## Refrigeration circuit

Refrigeration circuit with:

- filter dryer
- Ice Protection System: system to prevent ice on the bottom of air coil
- sight glass with moisture and liquid indicator
- high pressure safety pressure switch
- low pressure safety switch
- liquid receiver
- suction accumulator
- high pressure safety
- thermostatic expansion valve with equalizer
- 4-way reverse cycle valve
- non-return valve
- pressure probes

## Electrical panel

The capacity section includes:

- isolating transformer for auxiliary circuit power supply
- main line isolator switch
- compressor overload cutout switch
- fan fuses
- centrifugal pump motor protector
- compressor control contactor
- pump control contactor
- phase cutting fan speed controller (pressure)

Control keypad, including:

- 5 keys to turn the unit ON/OFF, change the operating mode, set the parameters and activate the controls
- a wide display that shows the water inlet/outlet setpoint, status and temperature
- remote installation until a 50m max. distance

The control section includes:

- set-point compensation with outdoor air temperature probe
- compressor overload protection and timer
- relay for remote cumulative fault signal
- dry contacts for compressor status
- dry contacts for external signals (unit operating status, alarms)
- set point compensation with 4-20 mA signal
- serial port with Modbus (RS 485) output for remote communication

## Hydraulic circuit

- water side safety valve
- impurity trap with filter
- centrifugal pump
- antifreeze heater protection to pumping station
- drain valve
- closed couple pumps with high efficiency impellers.

## Accessories

- PGFC – Finned coil protection grill
- 3DHWX - 3-way valve for domestic hot water
- PMX - Phase monitor
- AMRX - Rubber antivibration mounts
- CACSX - Domestic hot water kit control
- TASRX - Compartment for multifunction keyboard

## Configuration Code

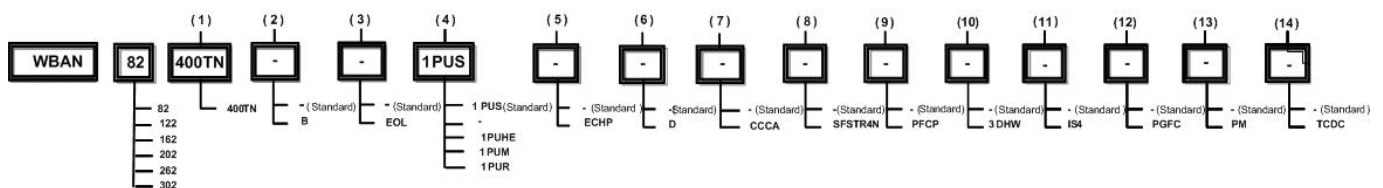

### (1) Supply voltage

400TN - Supply voltage 400/3/50+N  
Standard

### (2) Water low temperature

Water low temperature: not required (-)  
Standard

B - Water low temperature

this version allows unit operation in the range of water and glycol mix temperatures between +4 and -8°C

Two versions are available:

- Unit for low temperatures only
- Unit with double operating set-point

(Please contact our Sales office for special conditions)

### (3) Operating limit extension

Operating limit extension: not required (-)  
Standard

EOL - Operating limits extension

This version allows to reach a water temperature of 65°C, with an outdoor air temperature of between -7°C and +40°C

### (4) Utility side hydronic unit

1PUS - Standard pump  
Standard

Hydronic group utility side: not required (-)

1PUHE - High efficiency single inverter pump for primary circuit

1PUM - Single pump with larger available head

1PUR - Single pump with reduced available head

### (5) Ecobreeze fans

Ecobreeze fans: not required (-)  
Standard

ECHP - External fans with larger available head "ECOBREEZE"

### (6) Partial energy recovery

Partial energy recovery: not required (-)  
Standard

D - Partial energy recovery

Carried out using plate-type exchangers suited for recovering the desuperheating heat up to a maximum of 25% of the total unit heat.

### (7) Condensing coil

Standard condenser coil (-)  
Standard

CCCA - Copper / aluminium condenser coil with acrylic lining

### (8) Soft starter

Disposal for inrush current reduction: not required (-)  
Standard

SFSTR4N - Disposal for inrush current reduction, for unit 400/3/50+N

### (9) Power capacitors

Power factor correction capacitors: not required (-)  
Standard

PFCCP - Power factor correction capacitors (cosφ>0.9)

### (10) 3-way valve

Three-way valve: not required (-)  
Standard

3DHW - Built-in 3-way valve for domestic hot water on the unit  
Installed on board

### (11) Compressor insulation

Compressor insulation: not required (-)  
Standard

IS4 - Compressor insulation  
Installed on board

### (12) Protection grill

Finned coil protection grill: not required (-)  
Standard

PGFC - Finned coil protection grill  
Installed on board

### (13) Phase monitor

Phase monitor: not required (-)  
Standard

PM - Phase monitor  
Installed on board

### (14) Condensation collection pan

Condensate collection pan: not required (-)  
Standard

TCDC - Condensate collection pan with electric heater

## General technical data

Size			82	122	162	202	262	302
<b>Radiant panels</b>								
<b>Heating</b>								
Heating capacity	1	kW	31,0	41,4	53,3	73,9	83,3	103
Total power input	2	kW	7,04	9,93	13,0	17,5	20,6	25,3
COP (EN 14511:2011)	3		4,40	4,17	4,12	4,23	4,05	4,05
ErP Space Heating Energy Class - AVERAGE Climate - W35	11		A+	A+	A+	A+	A+	A+
SCOP - AVERAGE Climate - W35	12		3,24	3,63	3,42	3,70	3,45	3,19
<b>Cooling</b>								
Cooling capacity	6	kW	30,4	44,3	55,4	75,0	94,5	112,6
Total power input	2	kW	8,26	14,0	16,3	24,4	30,7	36,9
EER (EN 14511:2011)	7		3,69	3,18	3,39	3,08	3,07	3,05
Water flow-rate	6	l/s	1,44	2,10	2,62	3,56	4,48	5,34
Useful pump discharge head	6	kPa	157	153	148	164	138	166
<b>Terminal units</b>								
<b>Heating</b>								
Heating capacity	4	kW	29,1	40,3	51,0	71,1	80,4	99,5
Total power input	2	kW	8,53	12,1	15,5	20,8	24,8	30,8
COP (EN 14511:2011)	3		3,41	3,34	3,28	3,41	3,24	3,23
<b>Cooling</b>								
Cooling capacity	8	kW	21,3	32,2	39,7	53,9	65,9	80,3
Total power input	2	kW	7,79	12,5	14,9	21,9	27,6	32,1
EER (EN 14511:2011)	7		2,73	2,58	2,67	2,46	2,39	2,50
SEER	12		2,68	2,70	2,79	2,69	2,60	2,74
Water flow-rate	8	l/s	1,00	1,52	1,88	2,55	3,12	3,90
Useful pump discharge head	8	kPa	183	183	173	195	184	201
<b>Radiators</b>								
<b>Heating</b>								
Heating capacity	5	kW	27,4	40,1	48,6	69,3	78,4	98,2
Total power input	2	kW	10,3	14,9	18,4	25,3	29,9	37,6
COP (EN 14511:2011)	3		2,65	2,69	2,64	2,74	2,62	2,61
ErP Space Heating Energy Class - AVERAGE Climate - W55	11		-	A+	-	A+	-	-
SCOP - AVERAGE Climate - W55	12			2,95		2,99		
Water flow-rate	5	l/s	1,3	1,9	2,3	3,3	3,8	4,7
Useful pump discharge head	5	kPa	164	163	158	172	164	181
<b>Compressor</b>								
Type of compressors			SCROLL					
Refrigerant			R-407C	R-407C	R-407C	R-407C	R-407C	R-407C
No. of compressors		No	2	2	2	2	2	2
Oil charge (C1)		l	1,89	1,89	4,00	4,00	4,14	4,14
Oil charge (C2)		l	1,89	1,89	4,00	4,00	4,14	4,14
Refrigeration circuits		No	2	2	2	2	2	2
Refrigerant charge (C1)		Kg	7,5	10,0	15,0	16,0	20,0	19,0
Refrigerant charge (C2)		Kg	7,5	10,0	15,0	16,0	20,0	19,0
<b>Utility side exchanger</b>								
Type of exchanger	9		PHE	PHE	PHE	PHE	PHE	PHE
No. of exchangers		No	1	1	1	1	1	1
Water content		l	2,3	3,3	4,2	5,8	7,0	8,3
Minimum flow		l/s	0,9	1,1	1,4	1,75	2,1	2,3
<b>External Section Fans</b>								
Type of fans	10		AX	AX	AX	AX	AX	AX
No. of fans		No	4	4	6	6	8	8
Standard airflow		l/s	5000	5000	7420	7420	9585	9585
Installed unit power		kW	0,22	0,22	0,22	0,22	0,22	0,22



Size			82	122	162	202	262	302
<b>Hydraulic circuit</b>								
Maximum water side pressure		kPa	550	550	550	550	550	550
Safety valve calibration		kPa	600	600	600	600	600	600
Min. installation water contents		l	75	110	140	190	230	280
<b>Power supply</b>								
Standard power supply		V	400/3/50+N	400/3/50+N	400/3/50+N	400/3/50+N	400/3/50+N	400/3/50+N

The Product is compliant with the Erp (Energy Related Products) European Directive. It includes the Commission delegated Regulation (EU) No 811/2013 (rate heat output  $\leq 70$  kW at specified reference conditions) and the Commission delegated Regulation (EU) No 813/2013 (rated heat output  $\leq 400$  kW at specified reference conditions).

'Contains fluorinated greenhouse gases' (GWP 1773,85)

1. Entering/leaving water temperature user side 30/35°C, external exchanger entering air temperature 7°C (R.H. = 85%)
2. The overall power absorbed is calculated by adding the power absorbed by the compressor + the power absorbed by the fans + the power absorbed by the auxiliary electrical circuit + the percentage value of the pump to overcome pressure drops inside the unit
3. COP (EN 14511:2011) heating performance coefficient. Ratio between heating power delivery and power absorption per EN 14511:2011. The power absorption is the sum of the power absorbed by the compressor+auxiliary circuit+pump to overcome internal pressure drops
4. Entering/leaving water temperature user side 40/45°C, external exchanger entering air temperature 7°C (R.H. = 85%)
5. Entering/leaving water temperature user side 50/55°C, external exchanger entering air temperature 7°C (R.H. = 85%)
6. User side entering/leaving water temperature 23/18°C, external exchanger entering air 35°C
7. EER (EN 14511:2011) Performance coefficient in cooling. Ratio between cooling power delivery and power absorption in compliance with EUROVENT EN14511:2011. The total input is given by the compressor input + auxiliary electric circuit + percentage of power absorbed by the pump to prevent pressure drops inside the unit.
8. User side entering/leaving water temperature 12/7 °C, external exchanger entering air 35°C
9. PHE = plate exchanger
10. AX = axial fan
11. Seasonal Space Heating Energy Efficiency Class according to Commission delegated Regulation (EU) No 811/2013. W = Water outlet temperature (°C)
12. Data calculated according to the EN 14825:2016 Regulation

# Performance in Heating

Size	T <sub>ae</sub> (°C) D.B./W.B.	Internal exchanger water outlet temperature (°C)													
		35		40		45		50		55		60		65*	
		kWt	kWe	kWt	kWe	kWt	kWe	kWt	kWe	kWt	kWe	kWt	kWe	kWt	kWe
82	-15 / -15.4	15,2	5,14	15,0	5,70	14,9	6,33	14,8	7,04	14,8	7,78	-	-	-	-
	-10 / -10.5	18,1	5,34	17,8	5,94	17,5	6,60	17,4	7,37	17,2	8,15	17,1	9,08	-	-
	-7 / -8	20,0	5,44	19,7	6,06	19,3	6,75	19,1	7,54	18,8	8,35	18,6	9,31	19,0	9,3
	-5 / -5.4	21,3	5,51	20,9	6,14	20,5	6,85	20,2	7,65	19,9	8,48	19,6	9,47	20,0	9,5
	0 / -0.8	25,2	5,68	24,6	6,33	24,0	7,09	23,5	7,89	23,0	8,80	22,5	9,80	23,0	9,8
	7 / 6	31,3	5,89	30,4	6,59	29,4	7,39	28,6	8,21	27,7	9,21	26,9	10,2	27,4	10,2
	10 / 8.2	34,1	5,98	33,1	6,71	32,0	7,51	31,0	8,34	30,0	9,35	29,0	10,4	29,6	10,4
122	-15 / -15.4	21,0	7,78	20,9	8,50	20,9	9,33	21,2	10,3	21,5	11,3	-	-	-	-
	-10 / -10.5	25,1	8,03	24,7	8,82	24,7	9,74	25,0	10,8	25,2	11,9	25,1	13,4	-	-
	-7 / -8	27,5	8,18	27,1	9,01	27,0	10,00	27,3	11,2	27,5	12,3	27,3	13,8	27,8	13,8
	-5 / -5.4	29,2	8,27	28,8	9,13	28,7	10,1	28,9	11,4	29,1	12,6	28,9	14,1	29,5	14,1
	0 / -0.8	34,2	8,47	33,6	9,37	33,4	10,5	33,5	11,8	33,6	13,1	33,2	14,7	33,9	14,7
	7 / 6	41,7	8,74	41,0	9,69	40,6	10,9	40,5	12,3	40,5	13,7	39,6	15,4	40,4	15,4
	10 / 8.2	44,8	8,83	44,0	9,81	43,6	11,0	43,6	12,5	43,5	13,9	42,5	15,7	43,4	15,7
162	-15 / -15.4	26,5	9,65	26,2	10,4	25,9	11,3	25,7	12,3	25,6	13,3	-	-	-	-
	-10 / -10.5	31,7	10,2	31,3	11,0	30,8	12,0	30,5	13,1	30,1	14,2	29,7	15,4	-	-
	-7 / -8	35,2	10,4	34,6	11,3	34,1	12,4	33,6	13,6	33,1	14,7	32,6	16,0	33,3	16,0
	-5 / -5.4	37,5	10,6	36,9	11,6	36,2	12,7	35,6	13,9	35,0	15,1	34,5	16,5	35,2	16,5
	0 / -0.8	44,0	10,9	43,2	12,0	42,2	13,2	41,4	14,5	40,6	15,8	39,7	17,3	40,5	17,3
	7 / 6	53,8	11,3	52,6	12,5	51,3	13,8	50,0	15,2	48,8	16,7	47,6	18,3	48,6	18,3
	10 / 8.2	57,7	11,5	56,4	12,6	54,9	14,0	53,6	15,5	52,4	17,0	50,9	18,7	51,9	18,7
202	-15 / -15.4	40,0	13,2	39,5	14,3	39,1	15,6	38,8	17,1	38,5	18,6	-	-	-	-
	-10 / -10.5	46,6	13,8	46,1	15,1	45,5	16,5	45,1	18,2	44,8	19,8	44,6	21,8	-	-
	-7 / -8	50,4	14,1	49,7	15,4	49,3	17,0	48,9	18,7	48,5	20,4	48,3	22,5	49,3	22,5
	-5 / -5.4	54,1	14,4	53,2	15,8	52,7	17,4	52,2	19,2	51,6	21,0	51,2	23,1	52,2	23,1
	0 / -0.8	61,8	14,8	60,9	16,4	60,0	18,1	59,3	20,0	58,6	21,9	58,2	24,3	59,4	24,3
	7 / 6	74,4	15,5	72,9	17,2	71,8	19,1	70,8	21,2	69,9	23,4	69,0	25,8	70,4	25,8
	10 / 8.2	78,9	15,7	77,3	17,4	76,3	19,4	75,2	21,6	74,1	23,9	72,7	26,3	74,2	26,3
262	-15 / -15.4	44,8	15,5	44,5	16,8	44,4	18,5	44,4	20,4	44,5	22,3	-	-	-	-
	-10 / -10.5	52,1	16,1	51,6	17,6	51,3	19,4	51,2	21,4	51,2	23,5	51,3	26,0	-	-
	-7 / -8	56,3	16,4	55,7	18,0	55,4	19,9	55,2	22,0	55,0	24,1	55,1	26,7	56,2	26,7
	-5 / -5.4	60,4	16,8	59,6	18,4	59,4	20,3	59,0	22,5	58,6	24,7	58,4	27,4	59,6	27,4
	0 / -0.8	69,4	17,4	68,3	19,2	67,9	21,2	67,2	23,5	66,5	25,9	66,1	28,7	67,4	28,7
	7 / 6	83,9	18,4	82,2	20,3	81,2	22,5	80,1	25,0	78,9	27,5	77,7	30,4	79,3	30,4
	10 / 8.2	89,0	18,7	87,2	20,6	86,1	22,9	85,1	25,5	84,1	28,1	82,7	31,1	84,4	31,1
302	-15 / -15.4	56,3	19,5	55,8	21,2	55,5	23,2	55,3	25,2	55,1	27,3	-	-	-	-
	-10 / -10.5	65,0	20,3	64,6	22,3	64,1	24,5	64,0	27,0	63,9	29,5	63,9	32,5	-	-
	-7 / -8	70,1	20,7	69,5	22,7	69,0	25,1	68,8	27,8	68,6	30,4	68,8	33,7	70,2	33,7
	-5 / -5.4	75,2	21,1	74,6	23,2	73,9	25,7	73,6	28,6	73,4	31,4	73,3	34,7	74,8	34,7
	0 / -0.8	85,8	21,8	84,7	24,1	84,0	26,7	83,7	29,8	83,4	32,9	83,0	36,6	84,7	36,6
	7 / 6	104	23,0	102	25,4	101	28,2	99,9	31,6	99,1	35,0	98,1	39,0	100	39,0
	10 / 8.2	110	23,4	108	25,8	107	28,7	106	32,1	105	35,6	104	39,8	106	39,8

T<sub>ae</sub> [°C] = Entering external exchanger air temperature

kWt = Heating capacity in kW

kWe = Electrical power absorbed by compressors (kW)

Data listed in

The tables are based on plate exchangers without fouling and clean coils. For different situation it is necessary to use adequate correction factors.

Operation with extended operating limits version (EOL)

## Performances in cooling

Grandezze	To (°C)	Entering external exchanger air temperature (°C)											
		25		30		35		40		43		46	
		kWf	kWe	kWf	kWe	kWf	kWe	kWf	kWe	kWf	kWe	kWf	kWe
82	5	21,6	5,32	20,6	5,89	19,5	6,56	18,2	7,30	17,5	7,77	16,8	8,27
	7	23,4	5,39	22,2	5,98	21,0	6,66	19,7	7,39	19,0	7,86	18,1	8,37
	10	25,8	5,50	24,5	6,11	23,1	6,78	21,7	7,54	20,8	8,01	19,9	8,55
	12	27,5	5,57	26,0	6,22	24,7	6,89	23,1	7,64	22,1	8,16	21,2	8,64
	15	30,2	5,70	28,6	6,35	27,0	7,03	25,4	7,82	-	-	-	-
	18	33,5	5,79	31,8	6,42	30,1	7,12	-	-	-	-	-	-
122	5	33,2	9,14	31,5	10,0	29,8	11,1	28,0	12,4	26,8	13,2	25,9	14,0
	7	35,5	9,32	33,6	10,2	31,9	11,3	30,0	12,6	28,8	13,4	27,7	14,3
	10	38,8	9,57	36,8	10,5	34,8	11,6	32,8	13,0	31,5	13,9	30,4	14,7
	12	41,1	9,78	39,0	10,7	37,0	11,9	34,8	13,2	33,5	14,1	32,2	15,1
	15	44,9	10,1	42,6	11,1	40,4	12,3	38,0	13,6	36,6	14,6	35,2	15,6
	18	48,7	10,4	46,4	11,5	44,0	12,7	41,4	14,1	39,7	15,1	38,2	16,0
162	5	40,8	10,8	38,8	11,8	36,6	12,9	34,4	14,1	32,9	14,9	31,5	15,7
	7	43,9	11,0	41,6	12,1	39,4	13,2	36,8	14,4	35,3	15,1	33,8	16,0
	10	48,1	11,3	45,7	12,4	43,1	13,6	40,4	14,8	38,7	15,6	37,2	16,4
	12	51,2	11,5	48,7	12,6	46,0	13,8	43,2	15,0	41,2	15,9	39,4	16,8
	15	56,2	12,0	53,3	13,1	50,3	14,2	47,1	15,6	-	-	-	-
	18	61,2	12,4	58,1	13,5	54,9	14,7	-	-	-	-	-	-
202	5	55,4	16,1	52,6	17,6	49,9	19,4	47,2	21,3	45,5	22,6	43,8	23,8
	7	59,3	16,4	56,2	18,1	53,4	19,9	50,3	21,8	48,6	23,1	46,9	24,5
	10	64,8	17,0	61,8	18,8	58,7	20,6	55,2	22,8	53,2	24,1	51,3	25,5
	12	68,9	17,4	65,4	19,2	62,2	21,2	58,6	23,3	56,3	24,7	54,3	26,2
	15	75,2	18,1	71,2	20,0	67,6	22,0	63,9	24,1	61,4	25,7	59,1	27,2
	18	82,6	18,5	78,4	20,4	74,5	22,5	69,9	24,8	67,4	26,3	-	-
262	5	67,3	20,3	64,2	22,2	61,2	24,4	57,7	26,6	55,7	28,4	53,6	30,0
	7	72,2	20,8	68,9	22,8	65,4	25,0	61,8	27,4	59,5	29,0	57,5	30,7
	10	79,3	21,6	75,6	23,6	71,7	25,9	67,8	28,5	65,2	30,2	62,7	31,9
	12	84,6	22,3	80,6	24,3	76,2	26,7	72,2	29,3	69,8	31,0	66,9	32,8
	15	92,5	23,2	88,2	25,5	83,3	27,9	78,6	30,6	75,9	32,3	73,1	34,2
	18	104	23,8	98,9	26,1	93,8	28,5	88,4	31,3	85,2	33,0	81,8	35,0
302	5	82,4	23,8	78,5	26,2	74,1	28,7	70,2	31,6	67,9	33,8	65,2	35,8
	7	87,8	24,5	83,5	26,9	79,2	29,5	75,1	32,7	72,5	34,7	69,8	37,0
	10	96,7	25,7	91,7	28,1	87,3	31,0	82,3	34,1	79,3	36,2	77,0	38,6
	12	103	26,6	97,5	29,0	92,6	31,9	87,6	35,1	84,3	37,5	81,2	39,7
	15	112	28,0	106	30,6	101	33,5	95,7	36,9	91,7	39,3	-	-
	18	124	28,9	118	31,4	112	34,5	106	37,8	102	40,1	-	-

To (°C) = Leaving internal exchanger water temperature (°C)

kWf = Cooling capacity in kW

kWe = Electrical power absorbed by compressors (kW)

Performances in function of the inlet/outlet water temperature differential = 5°C

Data listed in the tables are based on plate exchangers without fouling and clean coils. For different situation it is necessary to use adequate correction factors.

# Operating limits

## Cooling



Tw [°C] = Exchanger outlet water temperature  
 Ta [°C] = Air temperature dry bulb

## Heating

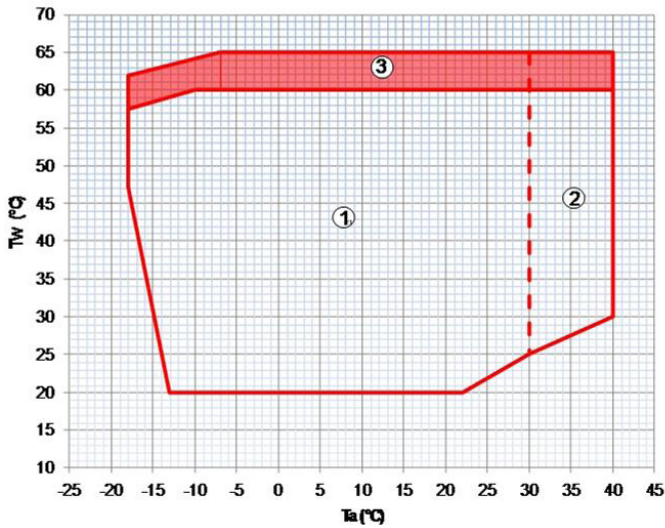

Ta = Entering air temperature to the external exchanger  
 Tw [°C] = Exchanger outlet water temperature  
 (1) Normal operating range  
 (2) Operation with modulating fans  
 (3) Operation with extended operating limits version (EOL)

## Electrical date

Size		82	122	162	202	262	302
<b>F.L.A. - Full load current at max admissible conditions</b>							
F.L.A. - Pump	A	1,90	2,70	2,50	3,20	3,20	4,80
F.L.A. - Total	A	24,1	34,3	42,7	55,1	67,1	80,5
<b>F.L.I. - Full load power input at max admissible conditions</b>							
F.L.I. - Pump	kW	1,00	1,40	1,36	1,76	1,76	2,93
F.L.I. - Total	kW	12,6	17,6	22,3	30,4	38,1	46,3
<b>M.I.C. Maximum inrush current</b>							
M.I.C. - Value	A	79,4	122	125	160	207	245
M.I.C. with soft start accessory	A	47,36	71,36	76,35	96,9	123,35	146,38

Power supply: 400/3/50 Hz +/- 10%

Maximum Phase Unbalance: 2%

The pump is included in the total values calculation

For non standard voltage please contact Clivet technical office

The units are compliant with the provisions of European standards CEI EN 60204 and CEI EN 60335.

## Sound levels

Size	Sound power level (dB)								Sound pressure level	Sound power level
	Octave band (Hz)									
	63	125	250	500	1000	2000	4000	8000	dB(A)	dB(A)
82	86	80	80	76	71	72	64	57	62	79
122	88	81	80	79	74	69	64	56	63	80
162	90	85	84	80	74	75	66	66	65	82
202	89	85	84	78	73	76	66	68	65	82
262	91	86	85	81	75	6	67	67	66	83
302	91	87	86	80	75	78	68	70	67	84

Measures according to ISO 3744 regulations, with respect to the EUROVENT 8/1 certification.

The sound levels of the internal unit refer to units at full load in normal test conditions.

The sound pressure level refers to a distance of 1 meter from the outer surface of the unit operating in open field.

Data referred to the following conditions:

internal exchanger water = 12/7°C

## Internal exchanger pressure drops

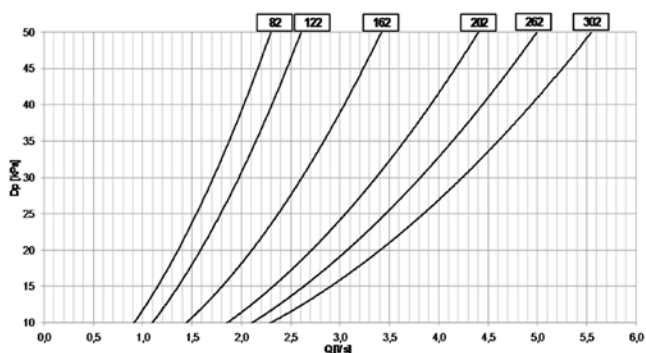

Exchanger pressure drop limit. Warning: don't use below this limit.

Q [l/s] = Water flow rate

DP = Pressure drop

Keep within the heat exchanger operating limits (upper and lower).

Exchanger pressure drop limit. Warning: don't use below this limit.

## Pump performance

### Curve of discharge head with standard pump (pump + water filter)

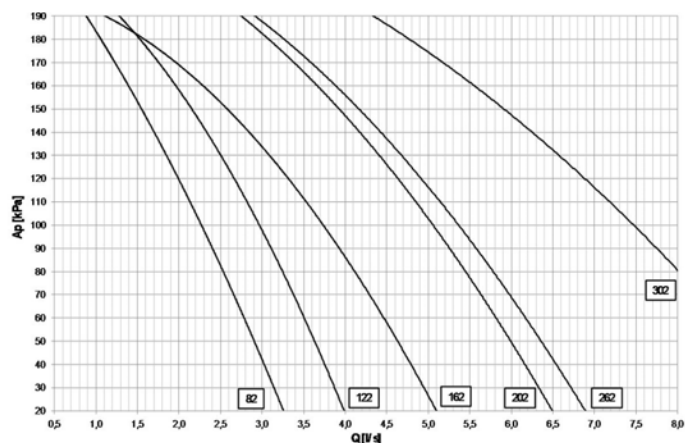

The heads are intended as available at the unit connections

Q [l/s] = Water flow rate

DP [kPa] = Available pressure

## Integrated heating capacities

Air temperature external exchanger inlet °C (D.B. / W.B.)	-5/-5,4	Others	5/3,9	0/-0,6
heating capacity multiplication coefficient	0,89	1	0,94	0,88

1. To obtain the integrated heating capacities (the real heating capacity considering the defrost cycles too), multiply the kWt value in the heating performance tables by the following coefficient.

## Correction factors for glycol use

% ethylene glycol by weight			5%	10%	15%	20%	25%	30%	35%	40%
Freezing temperature		°C	-2	-3,9	-6,5	-8,9	-11,8	-15,6	-19	-23,4
Safety temperature		°C	3,0	1,0	-1,0	-4,0	-6,0	-10,0	-14,0	-19,0
Cooling Capacity Factor		No	0,995	0,99	0,985	0,981	0,977	0,974	0,971	0,968
Compressor power input Factor		No	0,997	0,993	0,99	0,988	0,986	0,984	0,982	0,981
Internal exchanger glycol solution flow factor		No	1,003	1,01	1,02	1,033	1,05	1,072	1,095	1,124
Pressure drop Factor		No	1,029	1,06	1,09	1,118	1,149	1,182	1,211	1,243

The correction factors shown refer to water and glycol ethylene mixes used to prevent the formation of frost on the exchangers in the water circuit during inactivity in winter.

## Fouling Correction Factors

m <sup>2</sup> °C / W	Internal exchanger	
	F1	FK1
0.44 x 10 <sup>-4</sup>	1	1
0.88 x 10 <sup>-4</sup>	0,97	0,99
1.76 x 10 <sup>-4</sup>	0,94	0,98

The cooling performance values provided in the tables are based on the external exchanger having clean plates (fouling factor 1). For different fouling factor values, multiply the performance by the coefficients shown in the table.

F1 = Cooling capacity correction factors

FK1 = Compressor power input correction factor

# Configurations

## Operating limits extension (EOL)

The Extended operating limits version differs from the standard version (S) for the adoption of larger heat exchangers, allowing to reach a water temperature of 65°C with a thermal difference between inlet and outlet of 10°C, from an outdoor air temperature of between -7°C and +40°C.

In the "Operating range extension" version the thermoregulation is on the return temperature. The limit of 65°C can be reached by  $\Delta T=10K$  at the exchanger: the maximum allowed return temperature is 55°C. In cooling the thermoregulation is on the supply temperature.

The hot water production up to 65°C is obtained by performing the thermostatic temperature control on the water return temperature.

The maximum water return temperature is 55°C.

## General technical data - Operating limits extension (EOL)

Size			82	122	162	202	262	302
<b>Radiant panels</b>								
<b>Heating</b>								
Heating capacity	1	kW	31,0	41,5	53,4	74,0	83,3	102,6
Total power input	2	kW	6,90	9,58	12,9	17,1	20,6	24,9
COP (EN 14511:2011)	3		4,50	4,33	4,15	4,33	4,05	4,12
<b>Cooling</b>								
Cooling capacity	6	kW	29,9	44,3	55,4	74,0	91,9	110,9
Total power input	2	kW	8,20	13,6	16,3	24,4	31,1	37,4
EER (EN 14511:2011)	7		3,65	3,26	3,40	3,03	2,96	2,97
Water flow-rate	6	l/s	1,42	2,10	2,62	3,51	4,35	5,26
Useful pump discharge head	6	kPa	103	82	117	79	114	87
<b>Terminal units</b>								
<b>Heating</b>								
Heating capacity	4	kW	29,2	40,4	51,1	71,5	80,5	99,7
Total power input	2	kW	8,41	11,8	15,4	20,8	24,6	30,4
COP (EN 14511:2011)	3		3,47	3,42	3,32	3,44	3,27	3,29
<b>Cooling</b>								
Cooling capacity	8	kW	21,2	32,1	39,8	53,8	65,9	80,2
Total power input	2	kW	7,73	12,3	14,7	21,4	27,4	31,6
EER (EN 14511:2011)	7		2,74	2,62	2,70	2,51	2,41	2,54
ESEER	9		3,36	3,16	3,22	2,96	2,91	3,05
Water flow-rate	8	l/s	1,00	1,52	1,88	2,55	3,12	3,80
Useful pump discharge head	8	kPa	120	104	153	125	153	138
<b>Radiators</b>								
<b>Heating</b>								
Heating capacity	5	kW	27,3	40,2	48,3	65,7	79,6	100,1
Total power input	2	kW	11,4	16,4	19,9	27,3	32,6	41,1
COP (EN 14511:2011)	3		2,40	2,44	2,43	2,40	2,44	2,43
Water flow-rate	5	l/s	0,65	0,96	1,16	1,58	1,91	2,40
Useful pump discharge head	5	kPa	133	124	185	168	181	174
<b>Compressor</b>								
Type of compressors	SCROLL							
Refrigerant			R-407C	R-407C	R-407C	R-407C	R-407C	R-407C
No. of compressors	No		2	2	2	2	2	2
Oil charge (C1)	l		1,89	1,89	4,00	4,00	4,14	4,14
Oil charge (C2)	l		1,89	1,89	4,00	4,00	4,14	4,14
Refrigeration circuits	No		2	2	2	2	2	2

Size			82	122	162	202	262	302
Refrigerant charge (C1)		Kg	7,5	10,0	15,0	16,0	20,0	19,0
Refrigerant charge (C2)		Kg	7,5	10,0	15,0	16,0	20,0	19,0
<b>Utility side exchanger</b>								
Type of exchanger	10		PHE	PHE	PHE	PHE	PHE	PHE
No. of exchangers		No	1	1	1	1	1	1
Water content		l	3,3	4,2	5,8	7,0	8,3	10,1
Minimum flow		l/s	0,6	0,9	1,1	1,55	1,9	2,4
<b>External Section Fans</b>								
Type of fans	11		AX	AX	AX	AX	AX	AX
No. of fans		No	4	4	6	6	8	8
Standard airflow		l/s	5000	5000	7420	7420	9585	9585
Installed unit power		kW	0,22	0,22	0,22	0,22	0,22	0,22
<b>Hydraulic circuit</b>								
Maximum water side pressure		kPa	550	550	550	550	550	550
Safety valve calibration		kPa	600	600	600	600	600	600
Min. installation water contents		l	75	110	140	190	230	280
<b>Power supply</b>								
Standard power supply		V	400/3/50+N	400/3/50+N	400/3/50+N	400/3/50+N	400/3/50+N	400/3/50+N

- Entering/leaving water temperature user side 30/35°C, external exchanger entering air temperature 7 °C (R.H. = 85%)
- The overall power absorbed is calculated by adding the power absorbed by the compressor + the power absorbed by the fans + the power absorbed by the auxiliary electrical circuit + the percentage value of the pump to overcome pressure drops inside the unit
- COP (EN 14511:2011) heating performance coefficient. Ratio between heating power delivery and power absorption per EN 14511:2011. The power absorption is the sum of the power absorbed by the compressor+auxiliary circuit+pump to overcome internal pressure drops
- Entering/leaving water temperature user side 40/45°C, external exchanger entering air temperature 7 °C (R.H. = 85%)
- Entering/leaving water temperature user side 55/65°C, external exchanger entering air temperature 7°C (R.H. = 85%)
- User side entering/leaving water temperature 23/18°C, external exchanger entering air 35°C
- EER (EN 14511:2011) Performance coefficient in cooling. Ratio between cooling power delivery and power absorption in compliance with EUROVENT EN14511:2011. The total input is given by the compressor input + auxiliary electric circuit + percentage of power absorbed by the pump to prevent pressure drops inside the unit.
- User side entering/leaving water temperature 12/7 °C, external exchanger entering air 35°C
- ESEER calculated by EUROVENT, for systems featuring terminal units with water produced at 7°C
- PHE = plate exchanger
- AX = axial fan

## Operating Range (Heating)

Please refer to the operating limits:

(3) Operation with extended operating limits version (EOL). In this operating zone the thermoregulation is on the return temperature. The maximum return water temperature is 55°C with a delta T=10K at the exchanger

### Internal exchanger pressure drops

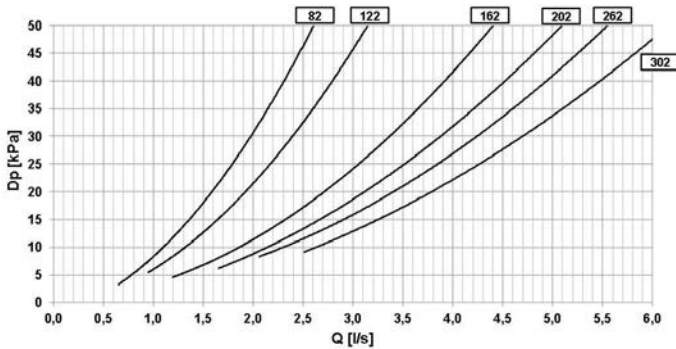

Exchanger pressure drop limit. Warning: don't use over this limit.

DP [kPa] = Pressure drops  
Q [l/s] = Water flow rate

Exchanger pressure drop limit. Warning: don't use below this limit.

### Pump performance

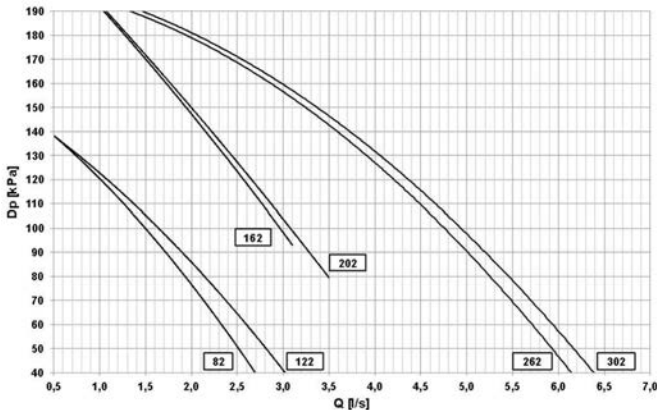

Available pressure curves with hydronic assembly

DP [kPa] = Available pressure  
Q [l/s] = Water flow rate

The heads are intended as available at the unit connections



## Hydronic blue utility side: not required (-)

The unit can be requested without circulating pump, expansion vessel, safety valve water side and filling assembly.

## 1PUHE - High efficiency single inverter pump for primary circuit

The high efficiency pump, is ideal for the connection of a primary circuit. It guarantees the necessary pressure to win the pressure drops of a circuit breaker, thanks to the DC inverter technology, it guarantees a reduced current draw increasing the unit efficiency.

Activate only when there is a call from the primary circuit, as a function of its temperature.

### Pump performance

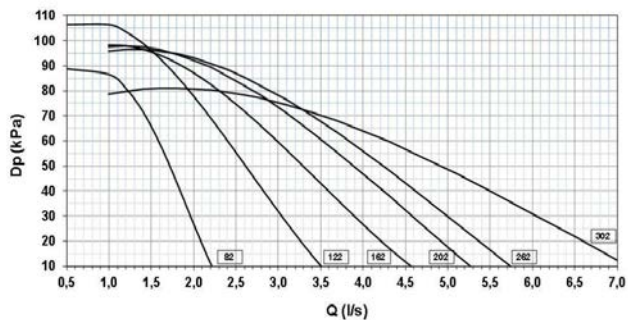

The heads are intended as available at the unit connections  
 Q [l/s] = water flow rate  
 DP [kPa] = Available pressure

### Pump absorption curves at high efficiency

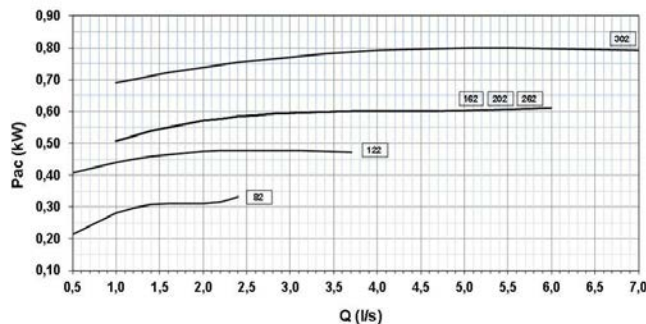

Q [l/s] = water flow rate  
 Pac (kW) = capacity absorbed by the pump

## 1PUM - Single pump with larger available head

Pump that ensures an available pressure exceeding 200 kPa

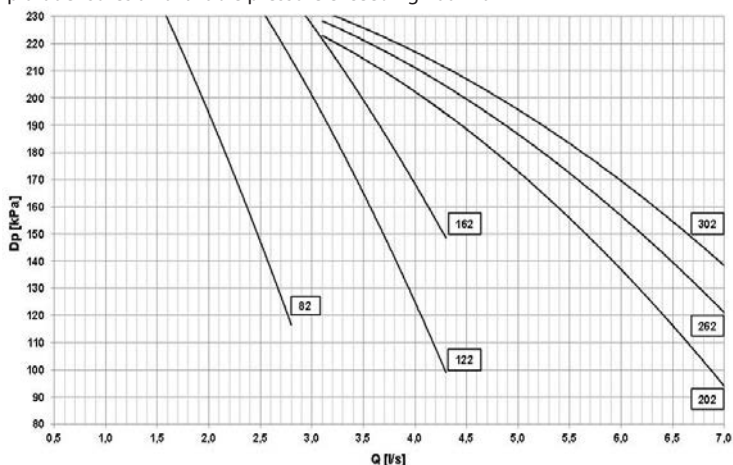

The heads are intended as available at the unit connections  
 Q [l/s] = Water flow rate  
 DP [kPa] = Available pressure

## 1PUR - Single pump with reduced available head

Pump that ensures an available pressure between 130 and 160 kPa

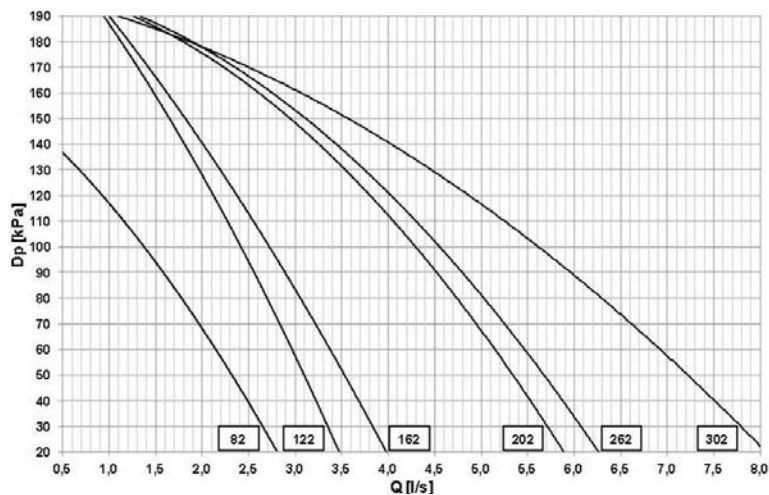

The heads are intended as available at the unit connections  
 Q [l/s] = Water flow rate  
 DP [kPa] = Available pressure

## ECHP - External fans with larger available head "ECOBREEZE"

This option is recommended for substantial reduction in the consumption of electrical energy for ventilation and to limit noise emissions in the external section of the machine.

The Eco-Breeze logic makes it possible to run the external axial fans with variable rotation speed based on the condensation pressure.

When fresh air temperature is low, a minimum air flow rate is required to hold down the condensation pressure.

Therefore, at low fresh air temperatures, fan rotation speed is reduced, resulting in reduced electricity consumption and noise emission (summer operation).

In case it's necessary to direct the supply air flow, Ecobreeze fans make available 30 Pa static pressure at rated flow.

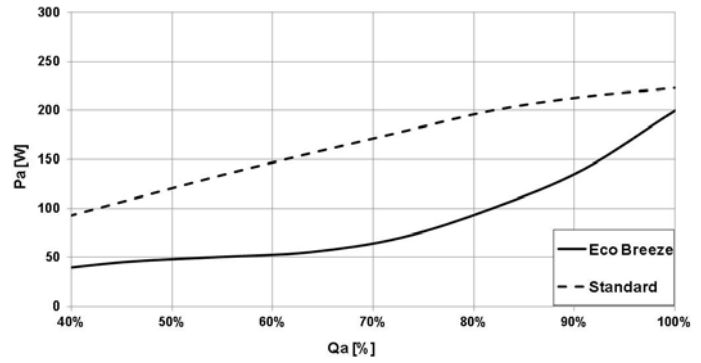

Pa (W) = Absorbed capacity by fans

## D - Partial energy recovery

. Partial recovery of condensing heat, up to 25%

A configuration which enables the production of hot water free-of-charge while operating in the cooling mode, thanks to the partial recovery of condensation heat that would otherwise be disposed of into the external heat source.

This option is also known as "desuperheater". It is made up of a 316 stainless steel brazed plate heat exchanger, suitable for recovering around one quarter of the heat capacity of the unit (equal to the sum of the cooling capacity and the electrical input capacity of the compressors).

The partial recovery device is considered to be operating when it is powered by the water flow which is to be heated. This condition improves the unit performance, since it reduces the condensation temperature: in nominal conditions the cooling capacity increases indicatively by 3.2% and the power input of the compressors is reduced by 3.6%.

When the temperature of the water to be heated is particularly low, it is wise to insert a flow control valve into the system hydraulic circuit, in order to maintain the temperature at the recovery output at above 35°C and thus avoid the condensation of the refrigerant into the partial energy recovery device.

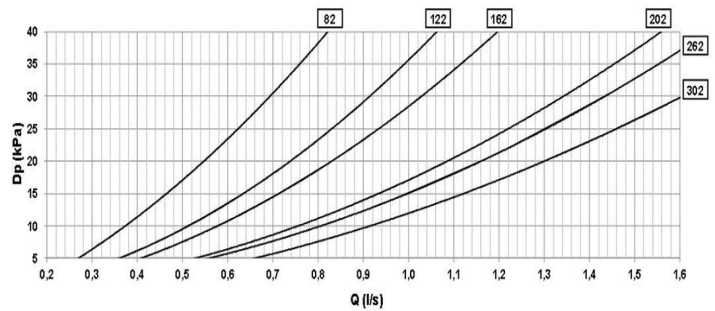

Q [l/s] = Water flow rate  
 DP = Pressure drop  
 Keep within the heat exchanger operating limits (upper and lower).

## CCCA - Copper / aluminium condensing coil with acrylic lining

The copper/aluminium evaporator coils with acrylic lining can be used in the room where the ambient air contains a concentration of salt and other not very aggressive agents.

## PFCP - Power-factor correction capacitors

The resetting condensers increase the power factor value, reducing the apparent current on the supply line to the chiller assembly



## 3DHW - Built in 3-way valve for domestic hot water on the unit

The unit is provided with a 3-way on/off valve to divert the flow of water to a hot water storage tank.

The 3-way valve is activated with the closure of a potential-free contact in the unit's electrical panel.

As soon as this function is enabled, the set point of the unit is placed at the value established by the appropriate parameter in the electronic control.

## SFSTR4N - Disposal for inrush current reduction, for unit 400/3/50+N

Starting up a motor directly can overload the electricity network, with start-up currents up to 8 times the nominal current.

Thanks to the breakaway current reduction device, start-up takes place gradually, with the start-up current being limited during this period of time.

The start-up current can therefore be reduced to 3.5 - 4 times the nominal current, meaning that the power systems and protection devices can be sized with lower parameters.

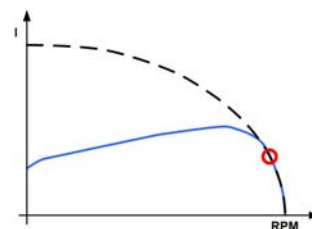

## IS4 - Compressor insulation

This attachment consists in an added cladding for compressors to reduce sound emissions.

## PGFC - Finned coil protection grill

The protection battery pack grilles, protect fins from accidental bumps.

## PM - Phase monitor

Phase monitor to check the presence and correct sequence of the power supply phases



## TCDC - Condensate collection pan with electric heater

In this configuration the standard base is replaced by a base in "aluzink" plate, the sides of which are formed the two drain trays.

The two drain trays, located under the coils, are equipped with Mylar antifreeze heaters applied on the bottom and a drain on the back side, on the water connection side.

We recommend the unit installation on a slight slope to facilitate the sliding of the condensate towards the drains.

The electric heaters are automatically activated at the end of each defrost cycle.

## Accessories

Every accessory is marked with a configuration code, for instance **CMMBX**.

When the letter X is placed at the end, this means that the accessory is supplied separately. If there is no X in the code, the accessory is mounted in the factory.

### PGFCX - Finned coil protection grill

The protection battery pack grilles, protect fins from accidental bumps.

### 3DHWX - 3-way valve for domestic hot water

The unit is provided with a 3-way on/off valve to divert the flow of water to a hot water storage tank.

The 3-way valve is activated with the closure of a potential-free contact in the unit's electrical panel.

As soon as this function is enabled, the set point of the unit is placed at the value established by the appropriate parameter in the electronic control.

### PMX - Phase monitor

phase monitor to check the presence and correct sequence of the power supply phases



### AMRX - Rubber antivibration mounts

The rubber antivibration mounts reduce the vibrations of compressor during its operation and they are installed at the base toe.

### CACSX - Domestic hot water kit control

The module makes it possible to control the temperature of a domestic hot water tank, not provided by Clivet.

The adjustment module comes with 2 temperature probes, 1 safety thermostat, power circuit and heating element control with protections against short circuits (the heating element is not provided by Clivet) and the installation box.

As opposed to the control of domestic hot water performed directly by the machine electronics, the kit makes it possible to set re-fill time periods and anti-legionella cycles, and to manage a re-circulation pump on the storage tank.

The storage tank must be suitably sized based on the combination with the selected heat pump.



### TASRX - Compartment for multifunction keyboard

This accessory permits to locate the multifunction keyboard on a different position.

The connection between the unit and the pocket reset must be made with a shielded cable 2 x 0.25. For details about the link please see the wiring diagram attached to the unit.

The maximum distance between the keypad support and the unit is 50m.



# Dimensionales and weight distribution WBAN 82-122

DACE21300 REV00  
DATA 24/03/2009

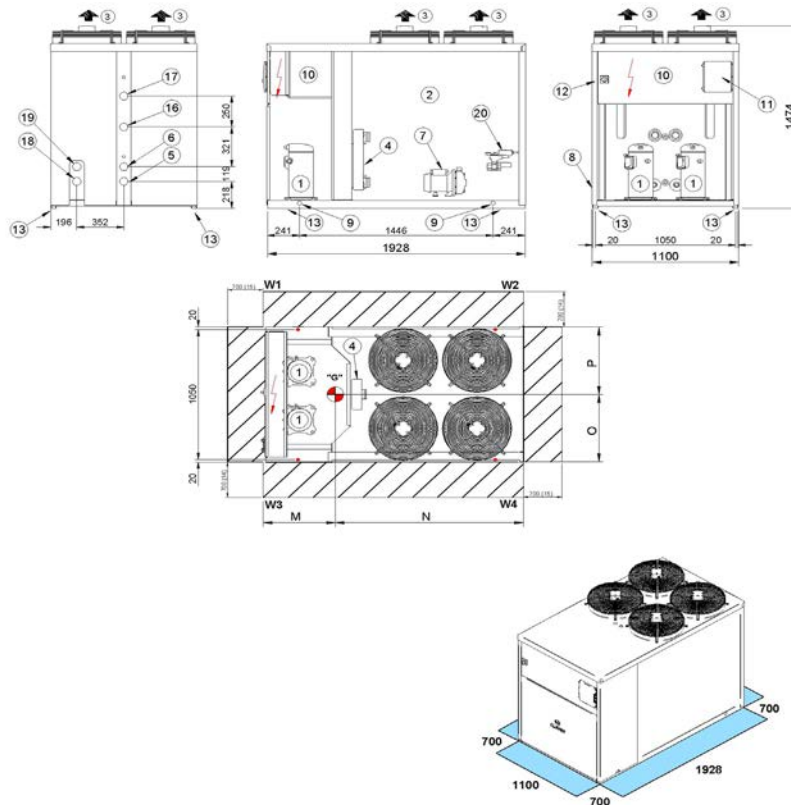

- |  |  |
|--|--|
| 1. Compressor                          | 14. Minimum Clearance for a Proper Air flow to the Condenser |
| 2. Finned exchanger                    | 15. Minimum Safe Clearance                                   |
| 3. Helical fans                        | 16. Desuperheater water inlet 1" 1/2 Victaulic               |
| 4. Plate heat exchangers               | 17. Desuperheater water outlet 1" 1/2 Victaulic              |
| 5. Exchanger water inlet 2" Victaulic  | 18. Domestic hot water input 2" Victaulic                    |
| 6. Exchanger water outlet 2" Victaulic | 19. Domestic hot water output 2" Victaulic                   |
| 7. Pump                                | 20. Three-way valve (optional)                               |
| 8. Power input                         | (G) Centre of gravity  |
| 9. Lifting holes                       | Victaulic connection joints                                  |
| 10. Electrical panel                   |  |
| 11. Microprocessor keyboard            |  |
| 12. Main isolator switch               |  |
| 13. Vibration mounts position          |  |

Size		82	122
M	mm	757	761
N	mm	1070	1045
O	mm	456	439
P	mm	549	549
Length	mm	1928	1928
Depth	mm	1100	1100
Height	mm	1474	1474
W1	kg	142	159
W2	kg	88	101
W3	kg	117	126
W4	kg	73	80
Operating weight	kg	420	466
Shipping weight	kg	430	474

The presence of optional accessories may result in a substantial variation of the weights shown in the table.

# Dimensionales and weight distribution WBAN 162-202

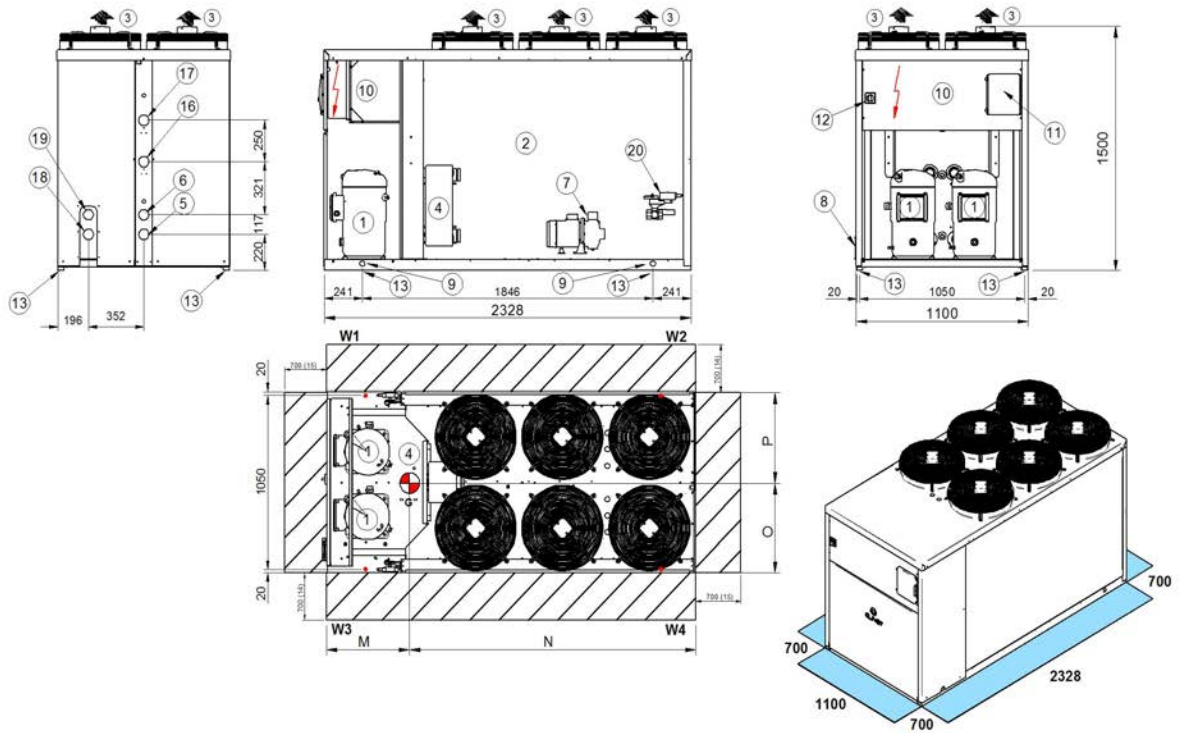

- 1. Compressor
  - 2. Finned exchanger
  - 3. Helical fans
  - 4. Plate heat exchangers
  - 5. Exchanger water inlet 2"Victaulic
  - 6. Exchanger water outlet 2"Victaulic
  - 7. Pump
  - 8. Power input
  - 9. Lifting holes
  - 10. Electrical panel
  - 11. Microprocessor keyboard
  - 12. Main isolator switch
  - 13. Vibration mounts position
  - 14. Minimum Clearance for a Proper Air flow to the Condenser
  - 15. Minimum Safe Clearance
  - 16. Desuperheater water inlet 1" 1/2 Victaulic
  - 17. Desuperheater water outlet 1" 1/2 Victaulic
  - 18. Domestic hot water input 2"Victaulic
  - 19. Domestic hot water output 2"Victaulic
  - 20. Three-way valve (optional)
- (G) Centre of gravity  
Victaulic connection joints

Size		162	202
M	mm	817	815
N	mm	1303	1386
O	mm	465	452
P	mm	550	554
Length	mm	2328	2328
Depth	mm	1100	1100
Height	mm	1500	1500
W1	kg	224	246
W2	kg	121	124
W3	kg	188	200
W4	kg	102	100
Operating weight	kg	635	670
Shipping weight	kg	647	681

The presence of optional accessories may result in a substantial variation of the weights shown in the table.

# Dimensionales and weight distribution WBAN 262-302

DACE2262 REV01  
DATA 11/01/2016

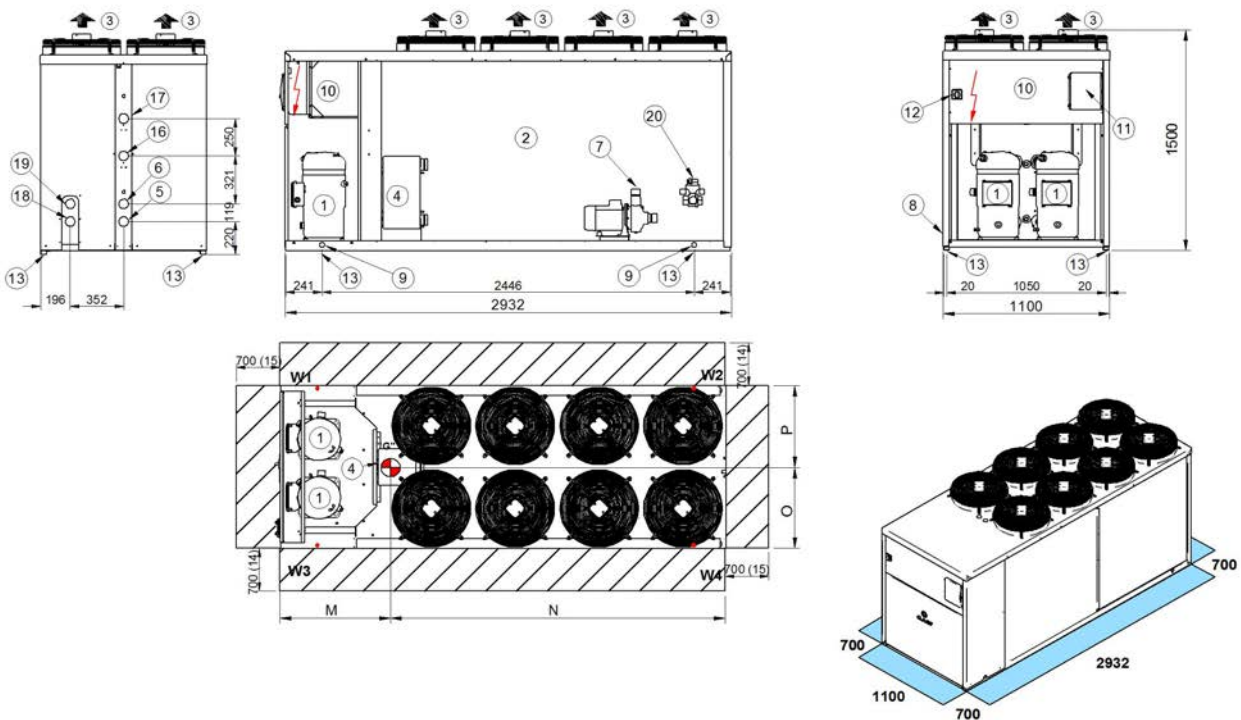

- 1. Compressor
  - 2. Finned exchanger
  - 3. Helical fans
  - 4. Plate heat exchangers
  - 5. Exchanger water inlet 2"Victaulic
  - 6. Exchanger water outlet 2"Victaulic
  - 7. Pump
  - 8. Power input
  - 9. Lifting holes
  - 10. Electrical panel
  - 11. Microprocessor keyboard
  - 12. Main isolator switch
  - 13. Vibration mounts position
  - 14. Minimum Clearance for a Proper Air flow to the Condenser
  - 15. Minimum Safe Clearance
  - 16. Desuperheater water inlet 1" 1/2 Victaulic
  - 17. Desuperheater water outlet 1" 1/2 Victaulic
  - 18. Domestic hot water input 2"Victaulic
  - 19. Domestic hot water output 2"Victaulic
  - 20. Three-way valve (optional)
- (G) Centre of gravity  
Victaulic connection joints

Size		262	302
M	mm	969	950
N	mm	1801	1824
O	mm	423	426
P	mm	576	575
Length	mm	2932	2932
Depth	mm	1100	1100
Height	mm	1500	1500
W1	kg	318	329
W2	kg	148	148
W3	kg	230	241
W4	kg	107	108
Operating weight	kg	803	826
Shipping weight	kg	814	834

The presence of optional accessories may result in a substantial variation of the weights shown in the table.



**CLIVET SPA**

Via Camp Lonc 25, Z.I. Villapaiera - 32032 Feltre (BL) - Italy  
Tel. + 39 0439 3131 - Fax + 39 0439 313300 - info@clivet.it

**CLIVET GROUP UK Limited**

4 Kingdom Close, Segensworth East - Fareham, Hampshire - PO15 5TJ - United Kingdom  
Tel. + 44 (0) 1489 572238 - Fax + 44 (0) 1489 573033 - enquiries@clivetgroup.co.uk

**CLIVET GROUP UK Limited (Operations)**

Units F5&F6 Railway Triangle Ind Est, Walton Road - Portsmouth, Hampshire - PO6 1TG - United Kingdom  
Tel. +44 (0) 2392 381235 - Fax. +44 (0) 2392 381243 - service@clivetgroup.co.uk

**CLIVET ESPAÑA S.A.U.**

C/ Bac de Roda, 36 - 08019 Barcelona - España  
Tel: +34 93 8606248 - Fax +34 93 8855392 - info@clivet.es

Av.Manoterás Nº 38, Oficina C303 - 28050 Madrid - España  
Tel. +34 91 6658280 - Fax +34 91 6657806 - info@clivet.es

**CLIVET GmbH**

Hummelsbütteler Steindamm 84, 22851 Norderstedt - Germany  
Tel. + 49 (0) 40 32 59 57-0 - Fax + 49 (0) 40 32 59 57-194 - info.de@clivet.com

**CLIVET RUSSIA**

Elektrozavodskaya st. 24, office 509 - 107023, Moscow, Russia  
Tel. + 74956462009 - Fax + 74956462009 - info.ru@clivet.com

**CLIVET MIDEAST FZCO**

Dubai Silicon Oasis (DSO), High Bay Complex, Office N. 20, PO BOX 342009, Dubai, UAE  
Tel. + 9714 3208499 - Fax + 9714 3208216 - info@clivet.ae

**CLIVET AIRCONDITIONING SYSTEMS PRIVATE LIMITED**

4BA, Gundecha Onclave, Kherani Road - Sakinaka, Andheri (East) - Mumbai 400 072 - India  
Tel. +91 22 6193 7000 - Fax +91 22 6193 7001 - info.in@clivet.com

[www.clivet.com](http://www.clivet.com)  
[www.clivetlive.com](http://www.clivetlive.com)

A Group Company of

